

# **BHUBANANANDA ORISSA SCHOOL OF ENGINEERING , CUTTACK**



## **DEPARTMENT OF ELECTRONICS AND TELECOMMUNICATION ENGINEERING LAB MANUAL**

**Year & Semester: 3<sup>RD</sup> Year, V Semester**

**Subject Code/Name: PR-3, WAVE PROPAGATION**

### **VISION OF THE DEPARTMENT-**

To be a center of excellence in the field of E&TC Engg by providing quality technical education as well as inculcating entrepreneurial skill, self-learning attitude and human values.

### **MISSION OF THE DEPARTMENT-**

- 1) To create an excellent infrastructure and teaching-learning environment for making the student acquire the knowledge needed.
- 2) To inculcate self-learning attitude, entrepreneurial skill and human values.
- 3) To impart knowledge required for recent & advanced Engg.

### **PROGRAM EDUCATIONAL OBJECTIVE-**

- 1) To apply knowledge of E&TC Engg. And principles of basic science & mathematics for analyzing the circuit of different electronics devices.
- 2) To compete for employment both in public and private sector.
- 3) To pursue higher study in E&TC as well as any other related branch for carrier enhancement.
- 4) To establish own assembly or service section with innovative, entrepreneurial ideas.
- 5) To work with team spirit and social ethics.

### **PROGRAM SPECIFIC OUTCOME-**

- 1) Use techniques and skills to design, analyze, synthesize and simulate electronics components and systems.
- 2) Architect, partition and select appropriate technology for implementation of a specified communication system.

### LIST OF THE EXPERIMENTS

SL. NO.	NAME OF THE EXPERIMENT
1	Study the Antenna Trainer for different type of Antenna
2	Draw the radiation pattern & find the characteristics of antenna (Yagi, Horn, Rombus, Dipole)
3	Find the standing wave ratio in transmission line.
4	Find voltage attenuation in transmission line
5	To study different types of micro wave components.
6	Measure VSWR of different types of load (Matched, Open, Shorted) using Micro wave test bench.
7	Setup and installation of Dish TV.
8	Study the operation of LED TV
9	Study of switch faults and trouble shooting in different section of LED TV.
10	Study the operation of mono chrome TV transmitter and receiver

## Aim of the Experiment 1

Arranging the setup and performing the functional checks of Antenna system.

### Connection Diagram



### Procedure

Main Unit:

- Place the main unit on the table and connect power cord.
  - RF Generator: Adjust level Potentiometer to Maximum Position
  - Modulation Generator: Select switch to 'INT' Position and adjust Level Potentiometer to Maximum Price.
  - Directional Coupler: Select the switch to 'FWD' position and adjust FSADJ Potentiometer to middleposition.
1. Install Transmitting mast , place it beside the main unit and connect it to the main unit 's' RF OUT' using BNC to BNC cable of 25" long.
  2. Install Receiving mast and keep it at some distance (around 1 meter) from the Transmitter mast.
  3. Place RF detector Unit beside the receiving mast and connect it to the receiving mast using a BNC to BNC cable of 25" long.
  4. Connect an Adapter+9V to the RF Detector unit , Switch it on and keep the Level knob at middleposition.
  5. Keep the base of Transmitting mast such that the '0' degree position of Gonio meter should be directed towards the RF Detector and also align the marker of the mast with '0' degree position.
  6. Install Detector Antenna on the Receiving mast .Keep its direction towards the Transmitting mast by rotating it in counter clockwise direction.
  7. Install 'Folded Dipole Antenna' on the Transmitting mast . Keep its direction towards the Receiving mast by rotating it in counter clockwise direction.
  8. Switch on the main unit and check the display in DPM of Directional Coupler. It will show some reading according to its level knob at starting.
  9. RF detector will also show some reading according to its level knob at starting .(In case of over loading, reduce it by level Potentiometer of RF detector)

10. Now vary the FS Adjust Potentiometer of Directional Coupler to make the display reading 100 Micro Amp and then adjust the Level of RF detector to show the  $\frac{3}{4}$  reading of the main unit's display.

## Aim of the Experiment 2

Plotting the Polar graph/radiation pattern of an Antenna manually

1. Get the setup ready as per the previous experiment
2. Ensure the following settings;
  - Transmitting mast marker is at '0' degree position.
  - Both, transmitting and receiving antennas are facing each other in horizontal plane.
  - Transmitter is tuned for maximum forward power to transmit and receive optimum/ maximum radiations for the antenna under test,
  - DPM for F Sad just at transmitting unit is set for 100μA and DPM at RF detector unit is set for 70μA.
3. Now to plot the Polar Graph/Radiation pattern of the transmitting antenna under test , start taking the readings at the interval 10 degrees and tabulate the degree v/s μA readings of RF detector unit display.
4. Convert the noted micro Amp readings into dBμ A with the help of the conversion chart given below. Following formula is used to convert the μA reading in to dB;

$$\text{dB}\mu\text{A} = 20 \log (\mu\text{A reading})$$

Degree	μA	dB μA	Degree	μA
0	70	37	190	-
10	-		200	-
-	-		-	-
-	-		-	-
180	-		360	-

5. Now plot the polar graph on the supplied polar graph paper as per the converted dBμ A readings against degrees of rotation as shown in next figure. A typical polar graph for folded dipole  $\lambda/2$  antenna is given in next figure.

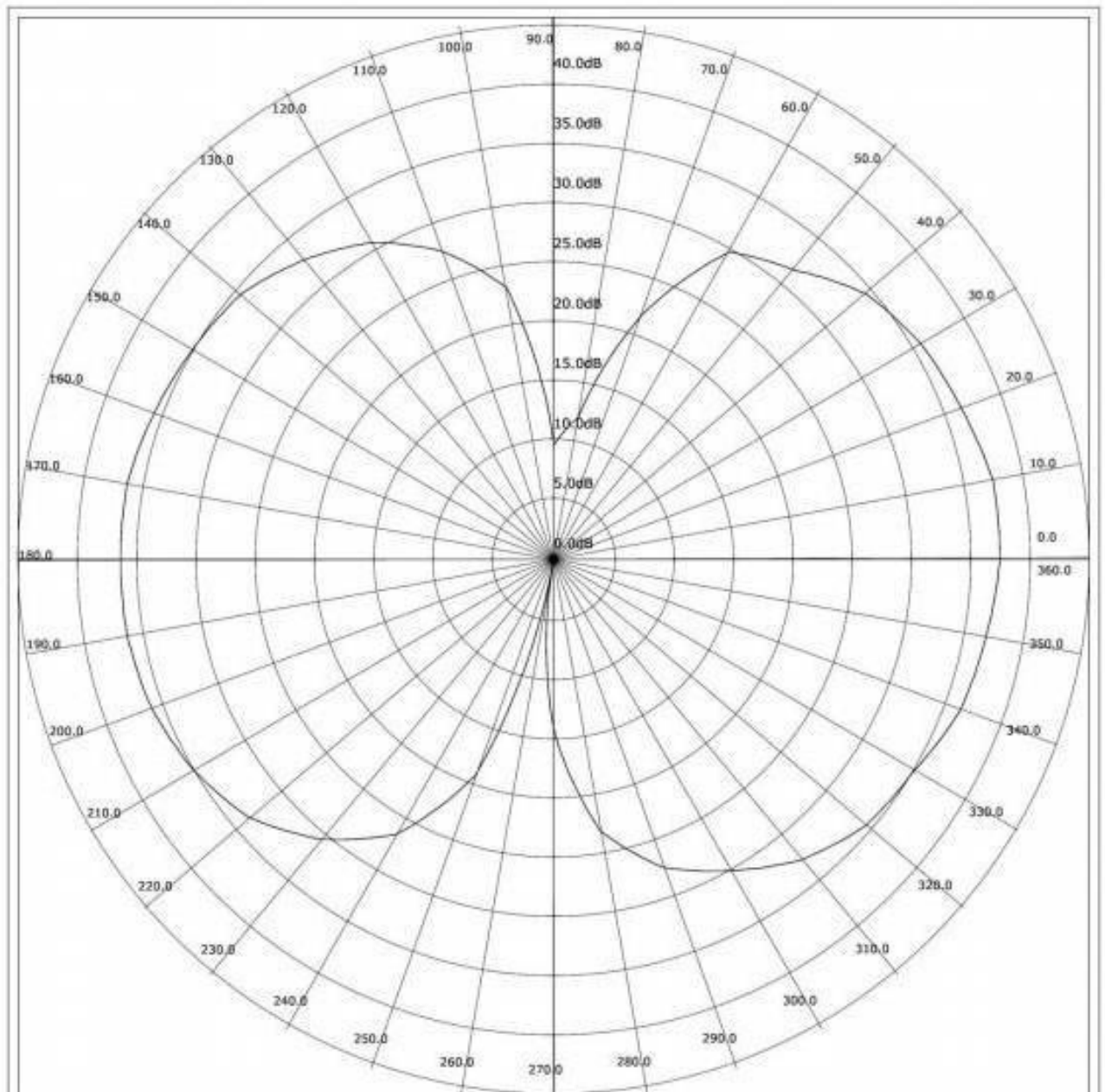

6. Calculate Beam width ,Front/ Back ratio ,Directive gain of antenna .To calculate the above from the graph, please refer next figure and proceed as follows. Beam width :Look for main lobe .Draw bore sight maxima line A A' Mark -3dB from maximum on the bore sight line point B. Draw an arc of radius AB This arc will intersect main lobe at C & D. Measure angle CAD This angle is - 3 dB beam width. Similarly calculate -10 dB beam width.

**Front to back ratio:**

Look for the main lobe. Draw bore sight maxima line A A' Look for back lobe if any(At 180)If no back lobe,then,

$$\text{Front to back ratio} = \frac{AA'}{1} \text{ dB}$$

If back lobe is present then , measure AE , where E is the maximum of back lobe

$$\text{Front to back ratio} = \frac{AA'}{AE} \text{ dB}$$

Since, we cannot have an idea isotropic antenna we presume here that its maximum radiation

intensity is 1 dB and is 100% efficient. Under this assumption Gain of antenna (or Directional Gain of antenna) is

$$G = \frac{AA' \text{ dB}}{1}$$

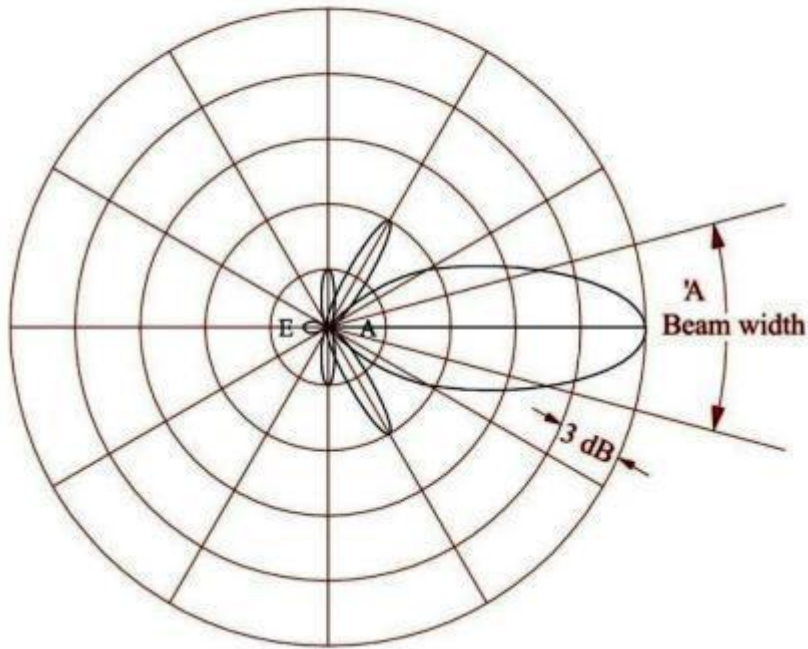

7. One can also plot the polar graph against normalized readings of RF Detector. The procedure to convert the Micro Amp into normalized reading is given as follows: Consider the maximum reading say N (When the RFD detector receives maximum radiations) as 0 dB. Let say it is N = 50 MicroAmp, Convert next reading taken at the interval (10 degrees) say N1 by the following formula:

$$\ln N1 / N = \text{reading in dB}$$

Let take N1 = 40 MicroAmp,  $\ln(40/50) = -0.22 \text{ dB}$  Follow the same procedure for the further readings thus the generalized formula will be:

$$\ln Nx / N = \text{readings in dB}$$

8. Now plot the polar graph on the supplied polar graph paper for normalized readings as per the converted dB readings against degrees of rotation.



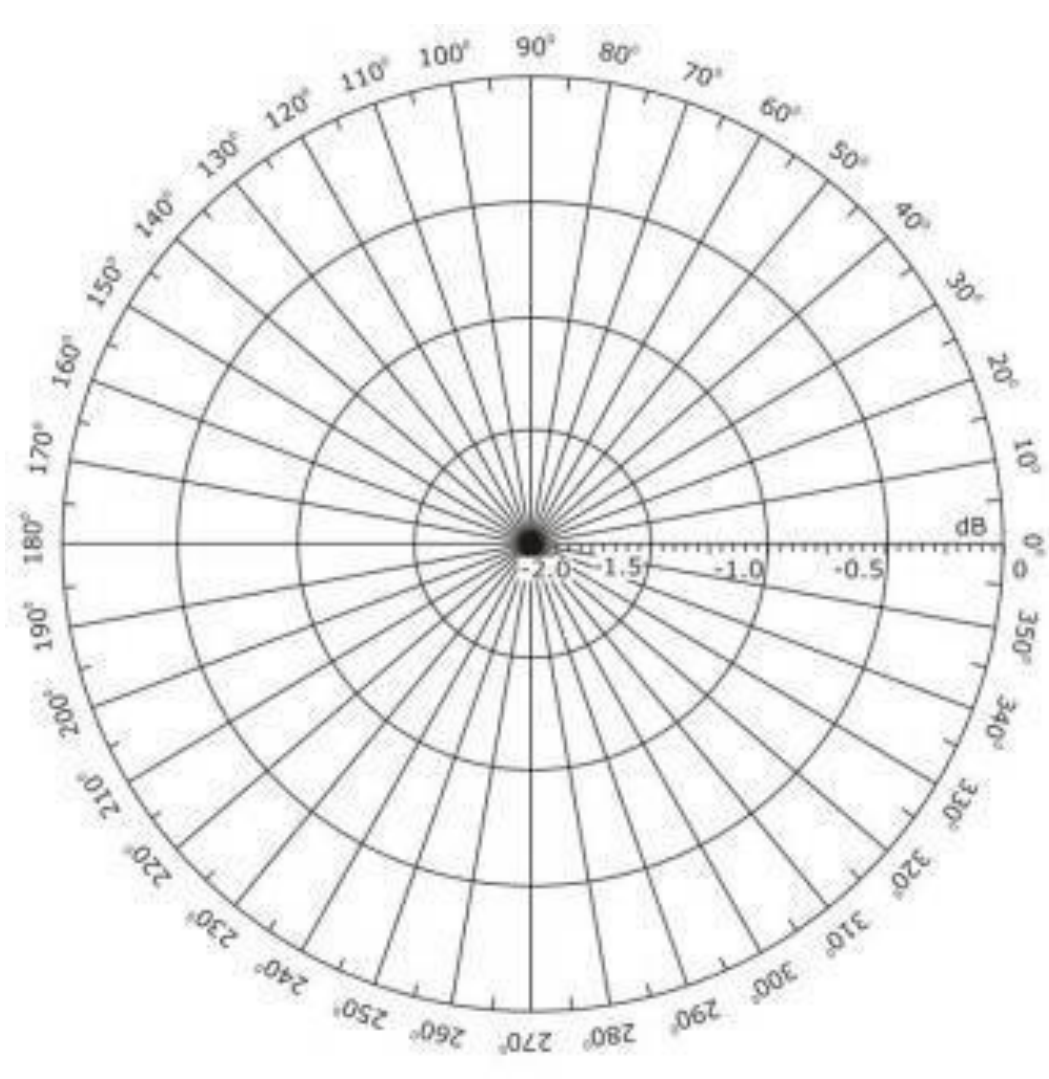

-

### **Aim of the Experiment 3**

To measure VSWR(Open and short circuit)in transmission line

### **Equipment Required**

1. Transmission Line Trainer kit
2. Cathode Ray Oscilloscope
3. Connecting wires
4. Digital Multimeter

### **Theory**

A line that has not been terminated with a load equal to its characteristic impedance is subject to a reflection phenomenon of the power from the remote end. The amount of the reflected power depends on the amount of mismatch between the characteristic impedance of the line and the load impedance . In the extreme cases of short circuited line( $R_L=0$ )and open line( $R_L=\infty$ )a situation of total reflection occur for either the current wave or the voltage wave.

### **Wiring Diagram**

Figure 1

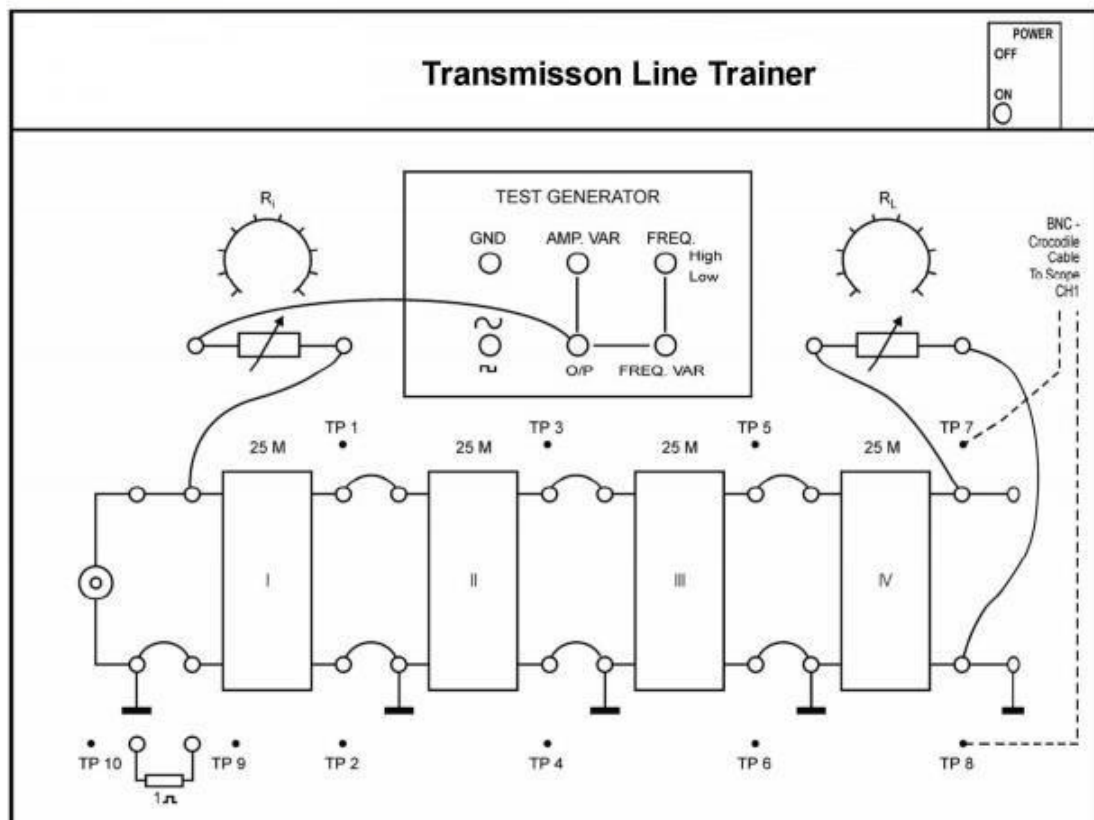

### **Procedure**

1. Adjust  $R_i$  and  $R_L$  for  $18\Omega$  and  $68\Omega$  respectively with the help of DMM.
2. Make connections as shown in Wiring Diagram

3. Set Oscilloscope to 0.1V/div for both channels.
4. Adjust the sine generator for an output of  $0.2V_{P-P}$  (2divDeflectionofCH1) and at frequency 100KHz
5. Observe the peak to peak voltages on CH2 at 100m d at intermediate sockets at 75m, 50m & 25m and 0m.
6. Tabulate results as under

Distance	$V_{P-P}$
0m	
25m	
50m	
75m	
100m	

7. Calculate the stationary wave ratio 's' by the following formula:  $s = V_{max}/V_{min}$   
For 100KHz 's' is approximately 1.25
8. The reflection coefficient 'r' of the line shows how much of the energy supplied at the input is being reflected as a consequence of the load decoupling. The reflection coefficient is normally expressed in percentage and can be determined from the stationary wave ratio through the following formula :  
 $r = (s-1)/(s+1)$   
At 100KHz 'r' is approximately 11%
9. Repeat the same procedure for open line & short-circuited line.
10. Try the experiment with other frequencies to see the effect of frequency on 's'

## Aim of the Experiment 4

To Measure the attenuation in Transmission Line

### Equipment Required

1. Transmission Line Trainer kit
2. Cathode Ray Oscilloscope
3. Connecting wires
4. Digital Multimeter

### Theory

The ohmic resistance  $R$  & the conductance  $G$  are responsible for energy dissipation in the form of heat. The losses which determine the attenuation characteristics, are expressed in terms of "attenuation" " $a$ " and can be calculated by:

$$a = 20 \log(V_2/V_1)$$

Where,

$V_1$  = amplitude of signal at input

$V_2$  = amplitude of signal at output

$a$  = attenuation for given length

In this experiment we will measure the attenuation for the different trunks of transmission line available on the trainer. See give figure below

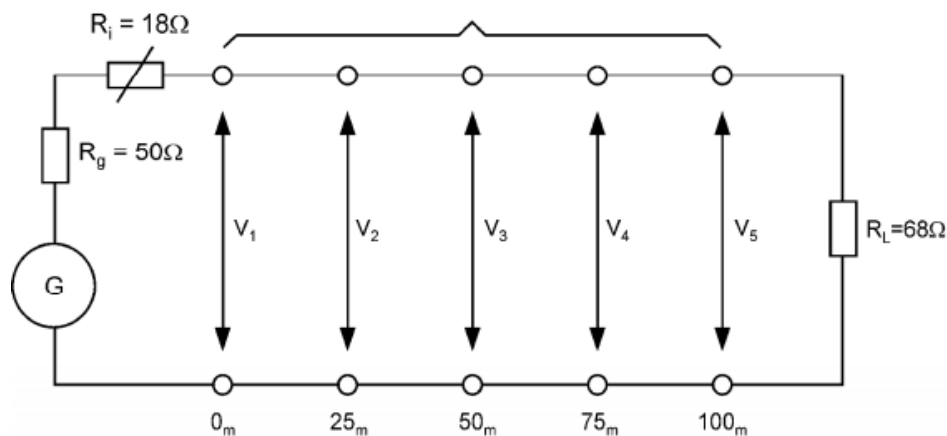

### Procedure

1. Adjust  $R_i$  and  $R_L$  for  $18\Omega$  and  $68\Omega$  respectively with the help of DMM.
2. Make connections as shown in Wiring Diagram.
3. Set the sine-wave frequency to approximately 100KHz and level to 0.4 V.
4. Oscilloscope CH1 shows applied input CH2 shows outputs.
5. Measure signal all even at Input, and at 25, 50, 75, and 100m lengths.
6. Tabulate as under:

Length (m)	V1(input)	V2(output)
25		
50		
75		
100		

7. Now, calculate the attenuations in dB at various lengths by the formula given below:

$$a = 20 \log V_2/V_1$$

8. The attenuation is approximately -2dB at 100m.

9. Try the same with open-ended line and short-ended line.

# WIRINGDIAGRAM

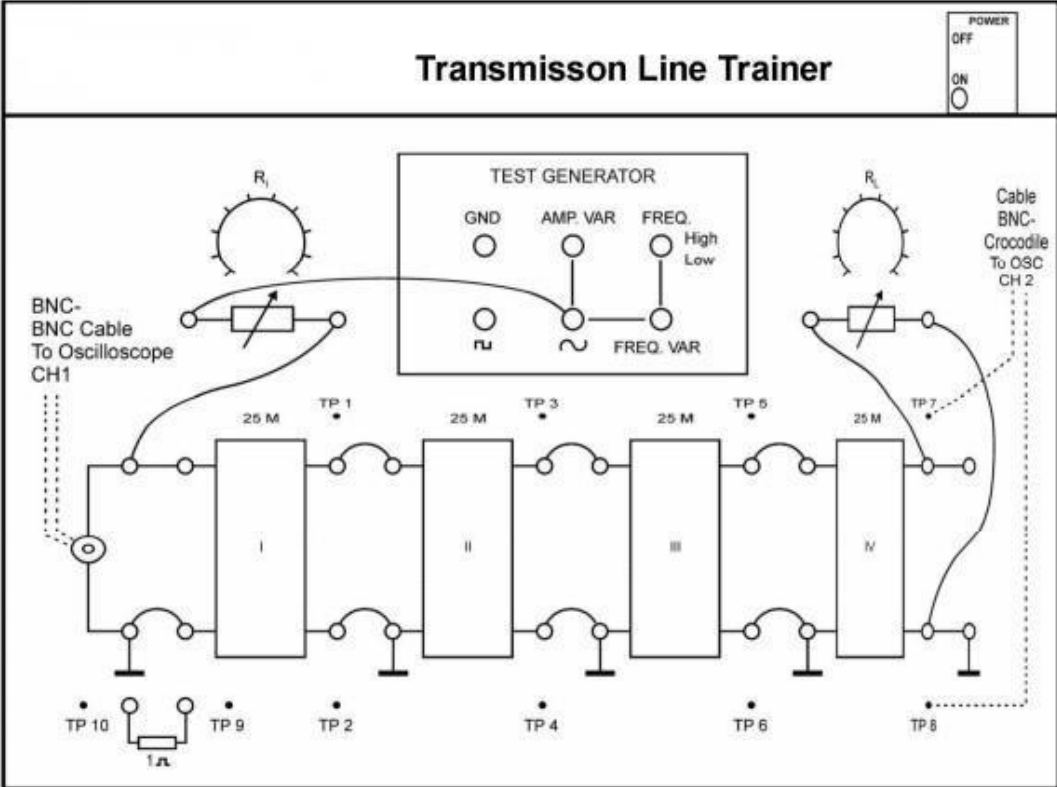

# CONCLUSION

AIM:-To study micro wave components.

APPARATUS REQUIRED :- Flanges, Twisted wave guide, wave guide tees, Directional Coupler, Attenuator, Isolators , Circulators , Matched terminator , Slide screw tuner , Slotted Section , Tunable probe, Horn antennas, Movable Short, Detector mount.

THEORY: - A pipe with any sort of cross- section that could be used as a wave guide or system of conductors for carrying electromagnetic wave is called a wave guide in which the waves are truly guided. (1) FLANGES: - Flanges are used to couple sections of wave guide components. These flanges are designed to have not only mechanical strength but also desirable electric characteristics.

(2) TWISTED WAVEGUIDE: - If a change in polarization direction is required, twisted section may be used. It is also called rotator. (3) WAVE GUIDE TEE: - Tees are junctions which are required to combine or split two signal sine wave guide .Different type of tees are:-(a)H-PLANETEE:- All the arm of the H- plane Tee lies in the plane of the magnetic field which divides among the arm. This is thus a current or parallel junction. (b) E- PLANE TEE: - It lies in the plane of electric field. It is voltage or series junction. In this signal is divided in to two parts having same magnitude but in opposite phase. (c) MAGIC TEE: - If another arm is added to either of the T-junction. Then a hybrid T- junction or magic tee is obtained. The arm three or four is connected to arm 1&2 but not to each other. (4) DIRECTION COUPLER :- The power delivered to a load or an antenna can be Measured using sampling technique in which a known fraction of the power is Measured so that the total may be calculated. A number of coupling units used for such purpose are known as directional coupler.

(5) ATTENUATORS: - It consists of a resistive wane inside the wave guide to absorb microwave power according to its position with respect to side wall of the wave guide. Attenuation will be maximum if the wane is placed at center.(a)Fixed Attenuators : In this the position of resistive wane is fixed, it absorbs constant amount of power. (b) Variable Attenuators: - In this the position of resistive wane can be changed with the help of micrometer. (6) ISOLATORS: - Ferrite is used as the main material in isolator. Isolator is a microwave device which allows RF energy to pass through in one direction with very little loss, while RF power in the reverse direction is absorbed. (7) CIRCULATORS: - A microwave circulator is a multi port junction device where the power may flow in the direction from 1 to 2, 2 to 3, & so on... (8) MATCHED TERMINATION: - A termination producing no reflected wave at any transverse section of the wave guide. It absorbs all the incident wave. This is also equivalent to connecting the line with its characteristic impedance. (9) SLOTTED SECTION: - A length of wave guide in which a non radiating slot is cut on the broader side. This is used to measure the VSWR. (10) SLIDE SCREW TUNER:- A screw or probe inserted at the top of wave guide (parallel to E) to develops us acceptance the magnitude & sign of which is controlled by depth of penetration of screw and it can be moved along the length of wave guide. (11) H - PLANE BEND: - An H-plane bend is a piece of wave guide smoothly bends in a plane parallel to magnetic field for the dominant mode (Hard bend). (12) E - PLANE BEND: - An E-plane bend is a piece of wave guide smoothly bends in a plane of electric field (Easy bend). (13) HORN ANTENNAS: - The components which radiates & intercept EM energy is of course the antenna. The open-ended wave guide, in which the open end is flared so that it looks like a horn, is called horn antenna. There are several types of horns – Sectional E-plane horn, Sectional H- plane horn and Pyramidal horn. (14) MOVABLE SHORT: - It is adjustable load which moves along the length of wave guide and adjusted to get SWR.

Conclusions : Study of various micro wave components has been made.

**AIM OF THE EXPERIMENT:5**

Measurement of Voltage Standing Wave Ratio using microwave testbench.

**EQUIPMENTAND COMPONENTS:**

- 1. Klystron power supplySKPS–610
- 2. Klystron tube 2k25
- 3. Klystron mount XM-251
- 4. IsolatorXI-621
- 5. Frequency meterXF-710
- 6. Variable attenuatorXA-520
- 7. Detector mountXD-451
- 8. Wave guide standsX4-535
- 9. VSWR meter SW-215
- 10. Movable short and S-S tuner

**THEORY:**

The reflex klystron makes use of velocity modulation to transform a continuous electron beam into microwave power. The electromagnetic field at any point of transmission line may be considered as the sum of to traveling waves the instant wave propagates from generator and the reflected wave propagates towards the generator .The reflected wave is set up by the reflection of instant wave from a discontinuity on the line or from the load impedance. The magnitude and face of the reflector wave depends up on amplitude and face of the reflecting impedance. The maximum field strength is found were two wave are in face and minimum were the two waves adds in opposite face. The distance between two successive minimum (or maximum) is half the guide wave length on the line.

The ratio electrical field strengths of reflected and incidents wave is called reflection coefficient .VSWR (voltage standing wave ratio) is defined as the ratio between maximum and minimum field strength along the line.

$$VSWR(S)=E_{MAX}/E_{MIN}$$

**BLOCKDIAGRAM:**

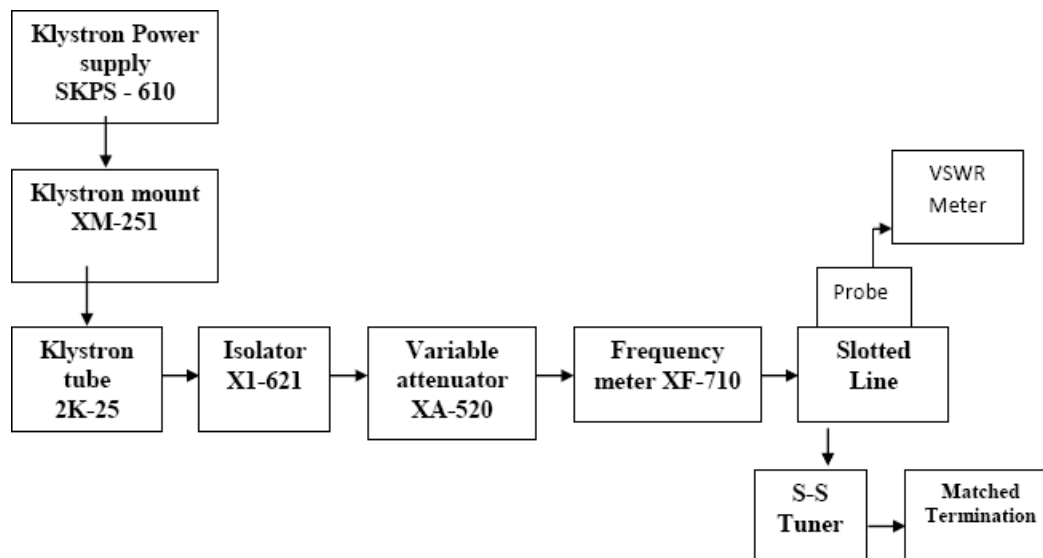

**PROCEDURE:**

**To fire klystron correctly, adopt the following procedure.**

- i. Set the cooling fan to blow air across the tube and turn on the filament voltage, and then wait for a few minutes.

- ii. Set the attenuator at a suitable level , say at 3db value.
- iii. Apply there peller voltage to its maximum value,say–250 V.
- iv. Then apply beam voltage say 250V,to obtain an electron beam indicated by beam current meter.Klystron is thus set to be oscillates and power output is indicated.
- v. Adjust there peller voltage to have maximum power output (micro ammeter current).
- vi. Also adjust the Klystron mounting plunger for maximum power output.
- vii. Set the depth of S- S tuner slightly more for maximum VSWR.
- viii. Move the probe along with slotted line until am in imum is indicated.
- ix. Adjust the VSWR meter gain control knob a variable attenuator to obtain a reading of 3 dB of normal dB of VSWR.
- x. Move the probe to the left on the slotted line until full scaled deflection is obtain note and record the probe position on slotted line let it be  $d_1$ .
- xi. Repeat step ix & x and then move the probe right along with slotted until full scale deflection is obtained let it be  $d_2$ .
- xii. Replace the S-S .Tuner and termination movable short.
- xiii. Measure the distance between two successive minima position of probe, Twice this distance is guide wave length  $\lambda_g$ .

$$SWR = \frac{\lambda_g}{\pi(d_1 - d_2)}$$

**OBSERVATIONS:**

Repeller voltage	Depth of S-S tuner	
	$d_1$	$d_2$

**CONCLUSION:**



## **Aim of the Experiment: 6**

### **Setup & Installation of Dish**

#### **TV Theory:**

In DTH television, the broadcast signals are transmitted from satellites orbiting the Earth to the viewer's house. Each satellite is located approximately 35,700 km above the Earth in geo synchronous orbit. These satellites receive the signals from the broad cast stations located on Earth and rebroadcast them to the Earth.

The viewer's dish picks up the signal from the satellite and passes it on to the receiver located inside the viewer's house. The receiver processes the signal and passes it on to the television.

In direct-to-home (DTH) telecast, TV channels/program mesa redirectly distributed via satellite to the subscribers ' homes without the intervention of a cable operator. The signals are transmitted in Ku band (10.7GHzto18GHz) and are received by the subscribers through a small dish antenna (about 45cm in dia.) and a set-top box (oran integrated receiver decoder). The DTH system can also provide many value- added services such as the Internet, e-mail, data casting, e-commerce, and interactive multimedia. It has the provision for a subscriber management system similar to the one for conditional access system (CAS). The current means of Broadcasting in India don't provide quality reception in shadow areas , particularly in thenorth-eastern region. The DTH can fill this void easily. All in all, DTH offers immense opportunities to both the broadcasters and the viewers. The detailed guide lines for starting the DTH service in India were issued by the government on March 15, 2001, followed by guidelines in March 2003 for up linking of foreign-owned news channels

The block diagram in figure 1 consists of following stages:

**1. Tuner section:**

- RF Tuner
- Conventional Mixer
- PLL

**2. Channel Decoder section:**

- ADC
- QPSK Demodulator
- Synchronizer Viterbi Decoder and R/S Decoder
- MPEG Transport De-multiplexer
- MPEG Decoder

**3. Microcontroller and Memory section**

- Control Processor
4. **Video output section**
  5. **Audio output section**
    - Stereo Audio DAC
    - Audio Amplifier
- Section
6. **Panel Control and Display section**
  7. **RF Converter section**
  8. **SMPS Power Supply section**

Signals from the Satellite situated in the geostationary orbit are received on the earth by the dish antenna. The signals after reflecting from dish antenna are focused LNB. LNB down converts these signals and send it to tuner of DTH receiver via co- axial cable.

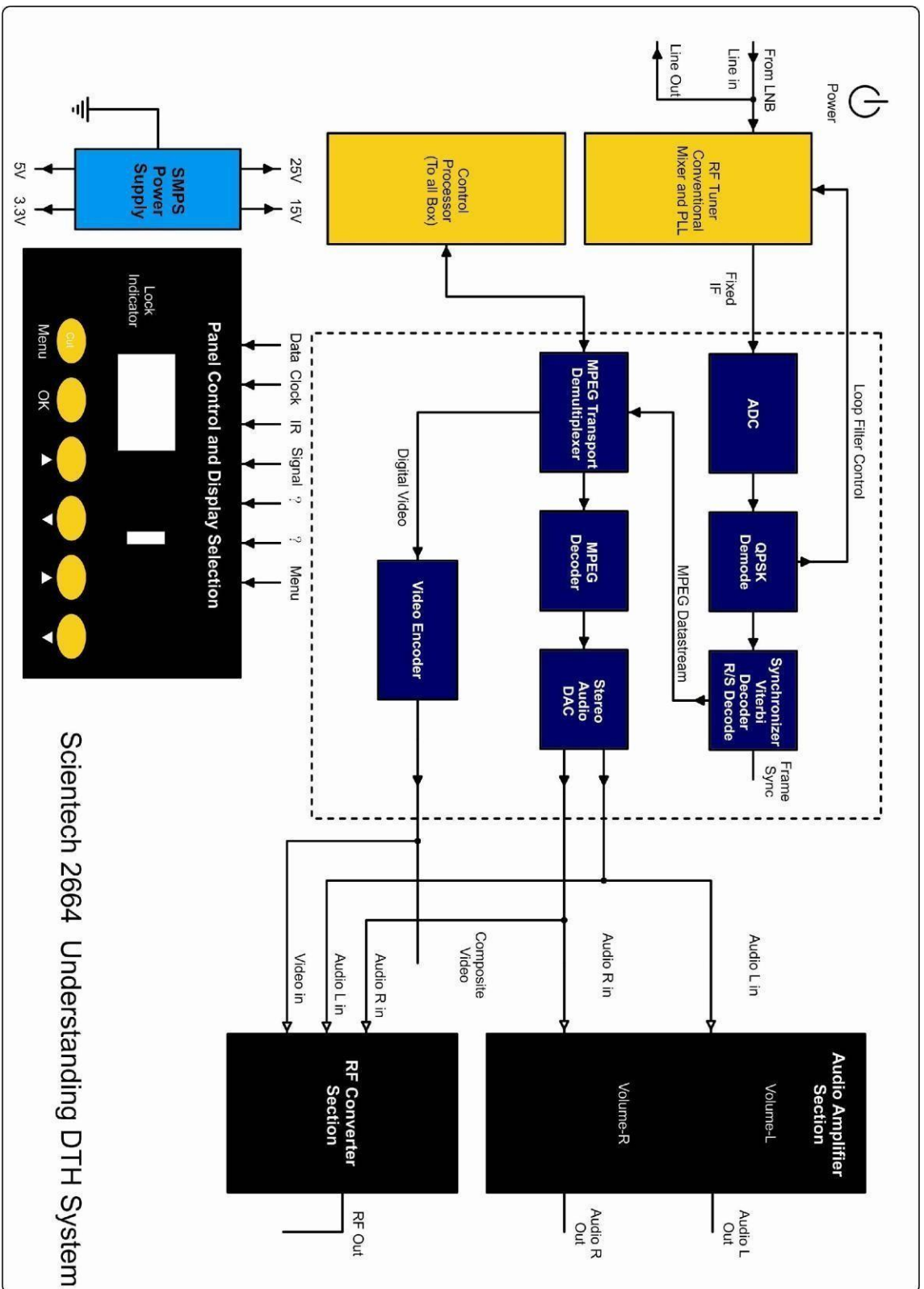

Scientech 2664 Understanding DTH System

Figure25

## **System Installation Procedure for Dish antenna**

### **Site Selection:**

- Preferably install the DTH antenna system through qualified and trained person. Locate the Place for the antenna installation.
  - There should not be any obstructions like trees, buildings, or any other objects towards satellite direction. This is the direction where satellite is available. There should not be any high power lines, terrestrial link lines or any kind of RF interference like RFI & EMI radiations near the site where the antenna is to be installed.
- The antenna mount is compatible for Wall and Ground Mount.
  - If you want to mount the antenna on the Wall or Ground please refer Antenna Assembly and Installation drawing.
  - First check all hardware items as per part list as mentioned in the drawing (Ground mount/ wall mount)
  - If you want to mount antenna on the wall , first check wall quality preferably select RCC wall which can provide better grip and strength to the stand. Do not install antenna on \_ Kachha' Wall.
  - If you want to mount antenna on the roof top (Terrace) make sure that it should be on RCC terrace with leveled Surface , if strength of terrace is not good than build standard RCC platform of 3 feet x 3 feet x 1 feet and then mount the ground mount stand as per following procedure.
- Following Procedure is same for wall mount and ground mount.

Conclusion:

## **Aim of the Experiment: 7**

Study the operation of a LED Television

### **Theory:**

This experiment explains how to connect and operate a LED Television in AV mode/ RF mode and use of Front Panel options.

### **Apparatus required:**

- Standard Video source(DVD/CD Player/RF Antenna)
- DVD/CD of compatible format(— .avi/.mpg/.mpeg/.mp3/.wma/.jpg/.jpeg||)
- Audio/Video Cable

### **Connection Diagram:**

- Connect the 34 pin FRC cable to the LED Monitor and Main board unit as shown in figure below. Ensure to take care of notch and direction of the cable to avoid the possibility of wrong connection.
- Connect the 15 Pin D Type cable to the LED Monitor and Main board unit as shown in figure below. Ensure to take care of notch and direction of the cable to avoid the possibility of wrong connection.

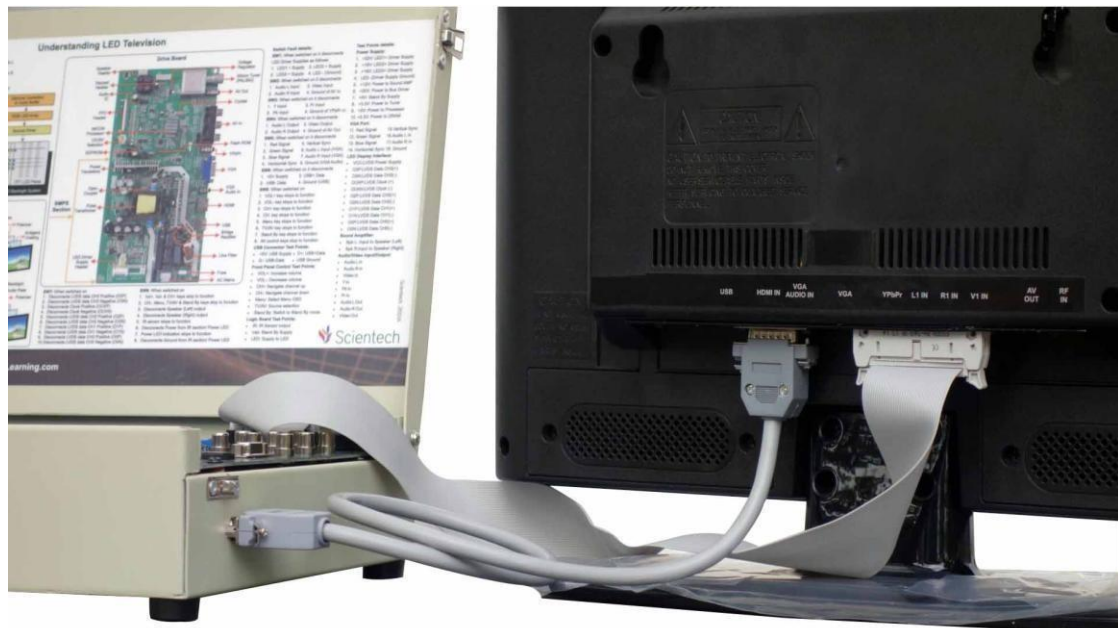

Figure 45

### **Operating Condition:**

- Check and ensure that the two cables (34pin FRC cable & 15 Pin D Type cable) are connected correctly and properly.
- Check that all the Switch Faults should be in 'off' position.

### **Procedure:**

1. Connect the mains cord to the unit and keep the switch to 'off' position till all the connections are carried out correctly and properly as per the connection diagram shown above. Ensure that the two cables (34pin FRC cable & 15 Pin D Type cable) are connected correctly and properly.
2. Check that all the switch faults on Scientech 2651A Main board unit are in 'off' position.
3. Connect Audio/Video input sockets of Scientech 2651A to the respective Audio and Video sockets of a DVD/CD player using the Audio/Video cable.
4. Switch on the DVD/CD player and insert a DVD/CD of a select the AV mode to operate it with LED Television in the tray.
5. Now switch on Scientech 2651A Main board unit.
6. Press 'Stand By' key of Front Panel Control section of Scientech 2651A to start the LED Television.
7. Press TV/AV key to select the operating mode and use 'CH+' key to select 'AV1' option and 'VOL+' key to enter.
8. Video output of DVD will start to display at LED Display screen . Play the video from DVD player.
9. Use 'VOL+'/'VOL-' keys of Front Panel Control of Scientech 2651A to set the volume.
10. Press 'Stand By' key to switch 'off' the unit.

### **Conclusion:**

## AIM OF THE EXPERIMENT 8

To study the common faults in LED TV.

### Apparatus required

1. Standard video source(DVD/CD Player/RF Antenna)
2. DVD/CD of compatible format
3. Audio/Video Cable
4. Oscilloscope(Sciencetech)
5. Multi-meter(Sciencetech)

### Operating Condition:

1. Check and ensure that the two cables are connected correctly and properly
2. Check that all the Switch Fault should be in 'off' position.

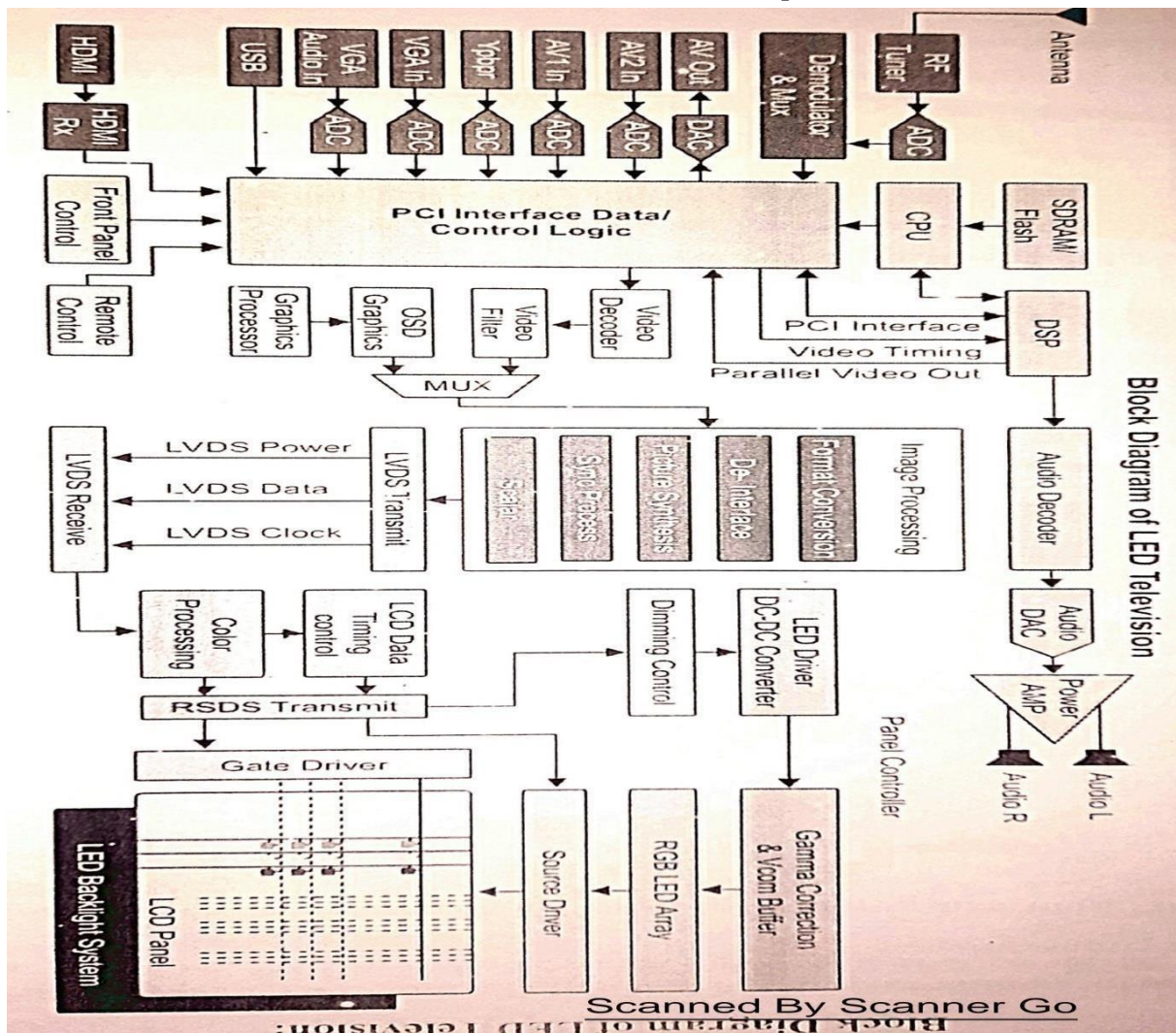

### PROCEDURE:

1. Connect the mains cord to the unit and keep the switch to 'off' position till all

The connections are carried out correctly and properly.

2. Check that all the switch faults on Scientech2651A main board unit are in “off” position.
3. Connect Audio/Video input socket of Scientech2651 At other respective Audio and Video socket of a DVD/CD player using the Audio/Video cable.
4. Switch on the DVD/CD player and insert a DVD/CD of as elect the AV mode to operate it with LED Television in the tray.
5. Now Switch on Scientech2651 main board unit.
6. Press “stand by” key of front panel control section of Scientech2651A to start the LED Television.
7. Press TV/AV key to select the operating mode and use ‘CH+’ key to select AV1 option and VOL+ key to enter.
8. Video output of DVD will start to display at LED Display screen. Play the video from DVD player.
9. Use ‘VOL+’/‘VOL-’ keys of front panel control to set the volume.
10. Use remote control function accordingly as and when required.
11. Create the switch fault one by one by switching the fault ‘on’ and observe the effect on different section as explain below.

#### NOTES:

1. Don’t let the switch fault in ‘on’ position for a long time ; it may damage the system permanently.
2. Don’t switch ‘on’ more than 1 fault at a time.
3. After switching the fault to ‘off’ position , if the system doesn’t take its effect back to operate properly, it is suggested to ‘restart’ the system again.

#### **SWITCH FAULT AND TROUBLESHOOTING:**

##### ➤ **Switch fault-Sw1: Power Supply Section**

1. Switch the fault 1.1 to ‘on’ position. Observe that the LED television stops to show the video display but audio signal can be heard. This fault causes to disconnected the +25-40V Driver Power supply to LED1+ channel. Check the signal at test point 1 of this section .Observe the difference in signal by switching the fault 1.1 to ‘off’ position.



2. Switch the fault 1.2 to 'on' position. Observe that the LED television stops to show the video display but audio signal can be heard. This fault causes to disconnect the +0V Driver Power supply to LED2+ channel. Check the signal at test point 2 of this section. Observe the difference in signal by switching the fault

1.2 to 'off' position.

3. Switch the fault 1.3 to 'on' position. Observe that the LED television stops to show the video display but audio signal can be heard. This fault causes to disconnect the +25-40V Driver Power supply to LED3+ channel . Check the signal at test point 3 of this section. Observe the difference in signal by switching the fault 1.3 to 'off' position.

4. Switch the fault 1.4 to 'on' position. Observe that the LED television stops to show the video display but audio signal can be heard. This fault causes to disconnect the common ground of Driver Power Supply (LED-).Check the signal at test point 4 of this section. Observe the difference in signal by switching the fault 1.4 to 'off' position.

➤ **Switch fault-Sw2: Audio/Video Input section**

1. Switch the Fault 2.1 to 'on' position. Observe that the LED screen stop to show the play back video. This fault causes to disconnect the video input signal to drive board. Without any video signal LED display stops to function. Check the video

Signal at 'Video' test point of this section . Observe the difference by switching the fault

2.1 to 'off' position.

2. Switch the fault 2.2to 'on' position. Observe that LED television stops to give the Left speaker output. This fault causes to disconnect the Audio L input signal to drive board. Check the audio signal at 'Audio L' test point of this section. Observe the difference by switching the fault 2.2 to 'off' position.

3. Switch the fault 2.3to 'on' position. Observe that LED television stops to give the Right speaker output .This fault causes to disconnect the Audio R input signal to drive board. Check the audio signal at 'Audio R' test point of this section.

Observe the difference by switching the fault 2.2 to 'off' position.

4. Switch the fault 2.4 to 'on' posit in. This fault causes to disconnect the common ground signal of Audio/Video source to Led Display logic board. Without properground the picture /audio quality reduces. Observe the difference in picture by switching the fault 2.4 to 'off' position.

**Switch Fault-Sw3:Y Pb Pr Input section:**

This section can be studied when respective in/out signal are available as and when

connected from standard source.

1. Switch the Fault 3.1 to 'on' position . Observe that the LED screen stops to show the playback video. This fault causes to disconnect the Y component of input signal to drive board. Without this signal LED display stops to function . Check the Y signal at 'Yin 'test point of this section. Observe the difference by switching the Fault 3.1 to 'off' position.

2. Switch the Fault 3.2 to 'on' position. Observe that the LED screen stops to show the playback video. This fault causes to disconnect the Pb component of input signal to drive board . Without this signal LED display stops to function. Check the Pb signal at 'Pb In' test point of this section. Observe the difference by switching the Fault 3.2 to 'off' position.

3. Switch the Fault 3.3 to 'on' position . Observe that the LED screen stops to show the playback video. This fault causes to disconnect the Pr component of input signal to drive board . Without this signal LED display stops to function . Check the Pr signal at 'Pr In' test point of this section. Observe the difference by switching the Fault 3.3 to 'off' position.

4. Switch the Fault 3.4 to 'on' position. This fault causes to disconnect the common ground signal of Y P b P r source to LED Display logic board. Without proper ground the picture/audio quality reduces. Observe the difference in picture by switching the Fault 3.3 to 'off' position.



